

Technical data

Pump name

100x80 FS2GCA 5 30

Customer	Date	2021-05-06	Company
Contact	Item no.		Issued by
Phone	Project		Phone
E-mail	Project ID		E-mail

Requested data

1	Pump type	End Suction Volute Pump	Fluid	Water
2	Number of pumps / Reserve	1 / 0	Liquid temperature	°C 20
3	Flow	m³/h	Kin. viscosity	mm²/s 1.005
4	Head	m	Vapour pressure	bar 0.0234
5	Geodetic head	m	PH value	
6	Inlet pressure (pin)	bar 0	Density	kg/dm³ 0.9983
7	Available system NPSH		Solids	Weight % 0
8	Ambient temperature	°C 20		

Pump

9	Pump name	100x80 FS2GCA 5 30	Frequency	Hz 50
10	Design	End Suction Volute Pump	Installation type	with base, motor
11	Manufacturer	EBARA	Impeller Diameter	Max. mm 193
12	Speed	rpm 2900		Designed mm 193
13	No. of Stage	1		Min. mm 166
14	Connection	Suction side JIS 10K	Flow	Operating m³/h
15	Connection	Discharge side JIS 10K		Max- m³/h 284
16	Max Working Pressure	bar 10		Min- m³/h 48
17	Shut-off head	bar 4.74	Head	Operating m
18	Total weight	kg See the table of "Dimensions".		- (Qmax.) m 21.5
19	Shaft power	kW		- (Qmin.) m 47.5
20			Max. Shaft Power at max. impeller	kW 27.08
21	Required pump NPSH	m	Efficiency	%

Materials

22	Casing	Cast iron	M.S.mating ring	Ceramic
23	Impeller	Bronze	M.S.seal ring	Carbon
24	Shaft	403 Stainless steel		
25	Casing ring	Bronze		
26	Ball bearing	.		
27	Mechanical seal	.		

Motor

28	Manufacturer	TECO	Insulation class	F
29	Type	200LA_B3_30_3_400	Phases	3~
30	Specific design	TEFC / 50 Hz / Pole pairs 1	Frame size	200 LA_30
31	Rated power	kW 30	Weight	kg 270
32	Number of poles	2	Electric voltage	V 400
33	Speed	rpm 2960	Electric current	A 55.2
34	Degree of protection	IP 55		
35				

Remarks

Performance curve

Pump name

100x80 FS2GCA 5 30

Customer	Date 2021-05-06	Company
Contact	Item no.	Issued by
Phone	Project	Phone
E-mail	Project ID	E-mail

Requested data

1	Flow	m ³ /h	
2	Head	m	
3	Geodetic head	m	

Pump

Operating Flow	m ³ /h	Frequency	Hz	50
Operating Head	m	Number of poles		2
Impeller Diameter Designed	mm	Speed	rpm	2900
	193			

Test standard: ISO 9906:2012 - Grade3B

Water; 20°C; 0.9983kg/dm³; 1mm²/s

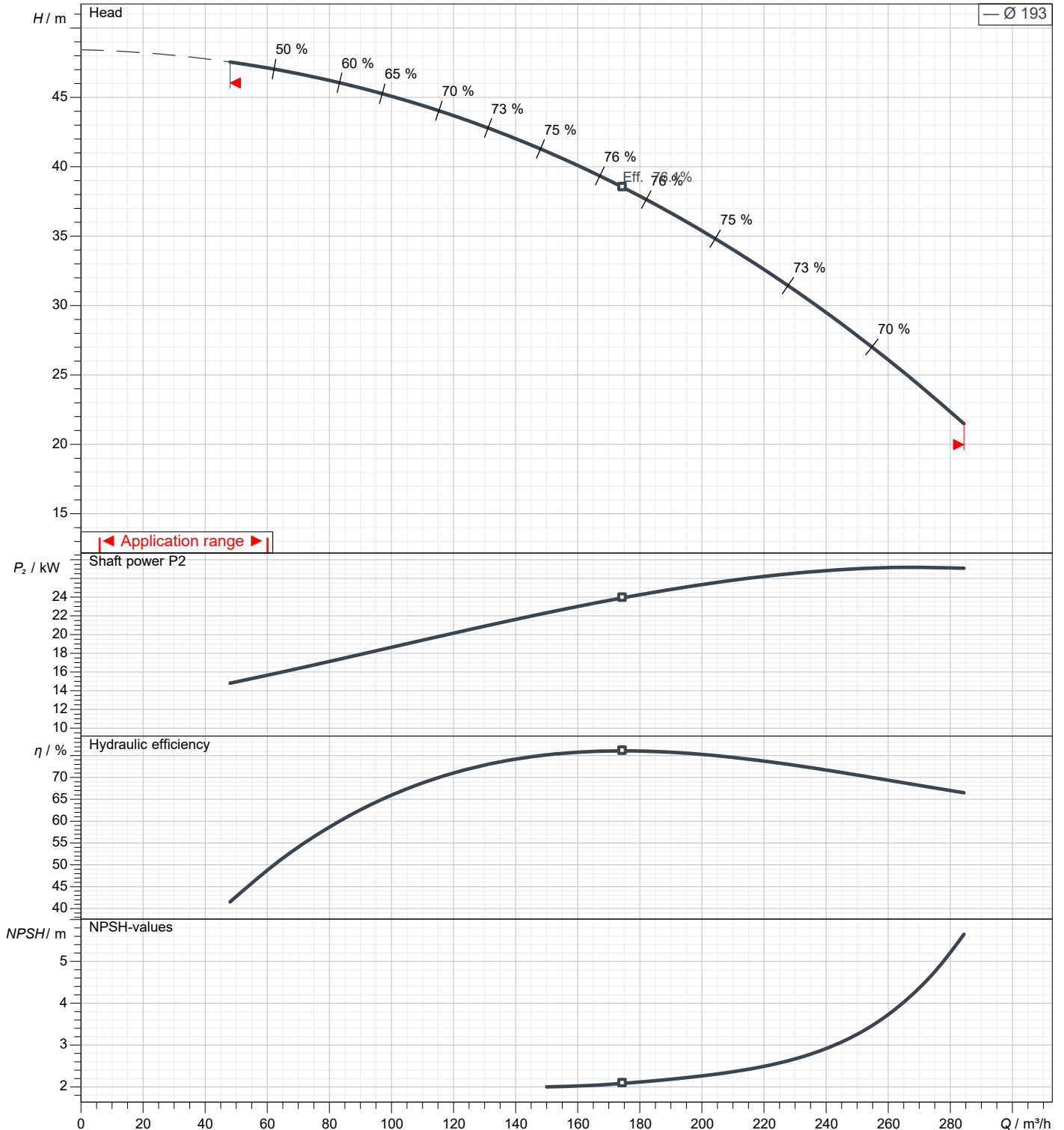

Dimensions

Pump name 100x80 FS2GCA 5 30

Customer	Date 2021-05-06	Company
Contact	Item no.	Issued by
Phone	Project	Phone
E-mail	Project ID	E-mail

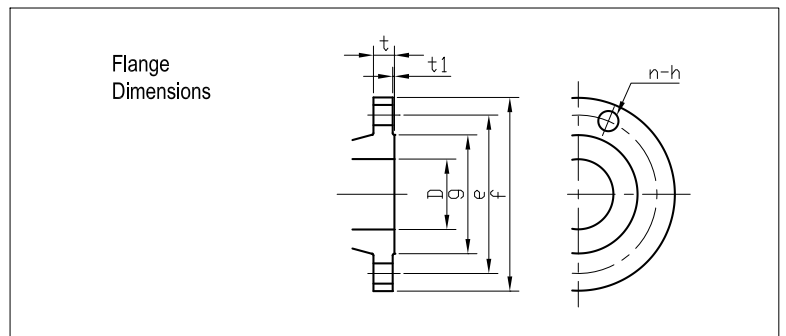
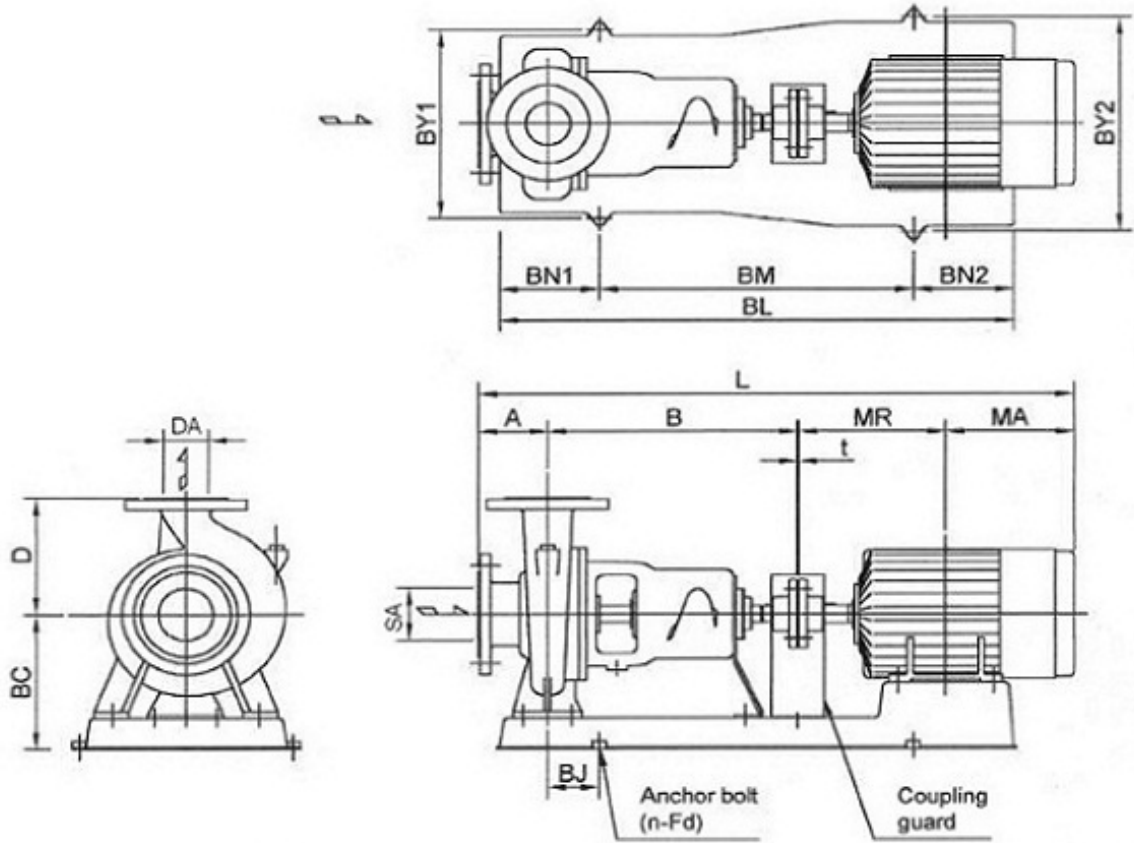

Total weight : 397 kg

Pump dimensions				Suction side		Discharge side	
mm				mm		mm	
A	125	MR	395.5	D	100	D	80
B	360	n	4 (Num)	e	175	e	150
BC	275	SA	100	f	210	f	185
BJ	95	t	4	g	151	g	126
BL	1040			h	19	h	19
BM	660			n Num	8	n Num	8
BN1	185			t	24	t	22
BN2	195			t1	2	t1	2
BY1	440						
BY2	440						
D	225						
DA	80						
Fd	M16						
L	1259						
MA	374.5						

(1/2)

Construction

Pump name 100x80 FS2GCA 5 30

Customer	Date 2021-05-06	Company
Contact	Item no.	Issued by
Phone	Project	Phone
E-mail	Project ID	E-mail

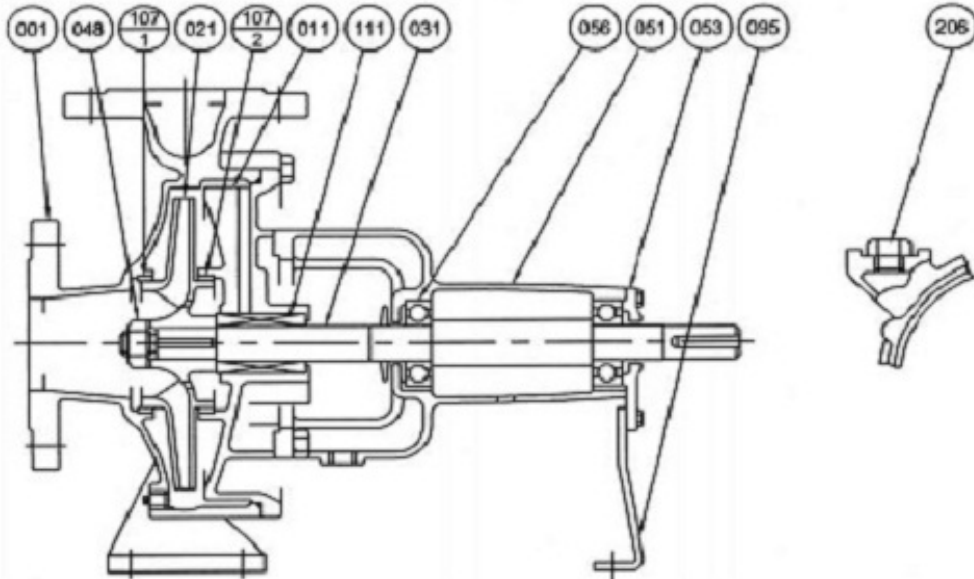

Model FH

50x40 FSHA; 65x50 FSHA, FSJA;
 80x65 FSGA, FSHA, FSJA, FSKA;
 100x80 FSGA, FSHA, FSJA;
 125x100 FSKA

Model EA

100x65 FSKA; 100x80 FSGCA, FSHCA;
 125x100 FSJCA, FSLA;
 150x100 FSKA, FSNA;
 150x125 FSHA, FSJA, FSKA, FSLA;
 200x150 FSHA, FSJA, FSKA, FSLA, FSNA;
 250x200 FSLA, FSNA

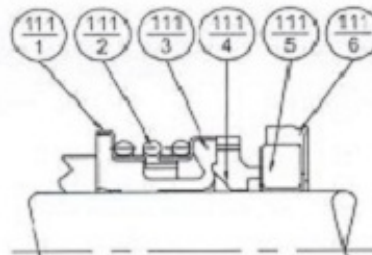
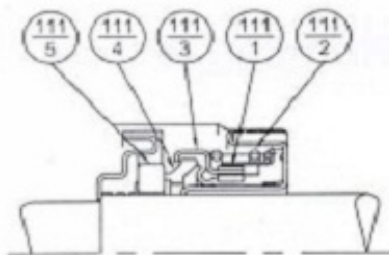

No.	Part Name	Material	Qty
111-5	Mating Ring	Ceramic	1
111-4	Seal Ring	Carbon	
111-3	Friction Ring	NBR	
111-2	Coil Spring	Stainless Steel	
111-1	Spring Holder		

No.	Part Name	Material	Qty
111-6	Cup Gasket	NBR	1
111-5	Mating Ring	Ceramic	
111-4	Seal Ring	Carbon	
111-3	Bellows	NBR	
111-2	Spring	Stainless Steel	
111-1	Spring Holder		

No.	Part Name	Material	Qty
207	Plug	Steel	1
111	Mechanical Seal	-	
107-2	Casing Ring	Bronze	1
107-1	Casing Ring		
095	Stay	Steel	1
056	Ball Bearing	-	2
053	Bearing Cover	Cast Iron	1
051	Bearing Housing		
048	Impeller Nut	Brass	1
031	Shaft	Stainless Steel	
021	Impeller	Bronze	
011	Casing Cover	Cast Iron	
001	Casing		

Customer	Date 2021-05-06	Company
Contact	Item no.	Issued by
Phone	Project	Phone
E-mail	Project ID	E-mail

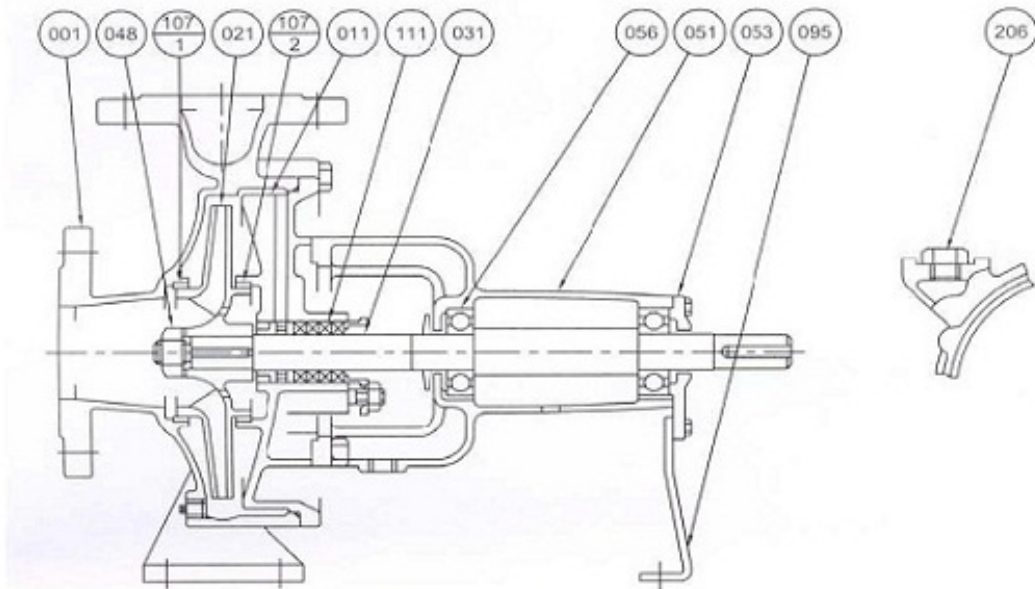

With Lantern Ring

50x40 FSHA; 65x50 FSHA, FSJA;
 80x65 FSGA, FSHA;
 100x80 FSGA; 125x100 FSLA;
 150x100 FSKA, FSNA;
 150x125 FSKA, FSLA;
 200x150 FSJA, FSLA, FSNA;
 250x200 FSLA, FSNA

Without Lantern Ring

80x65 FSJA, FSKA;
 100x65 FSKA;
 100x80 FSHA, FSJA, FSGCA, FSHCA;
 125x100 FSJCA, FSKA;
 150x125 FSHA, FSJA;
 200x150 FSHA, FSKA;

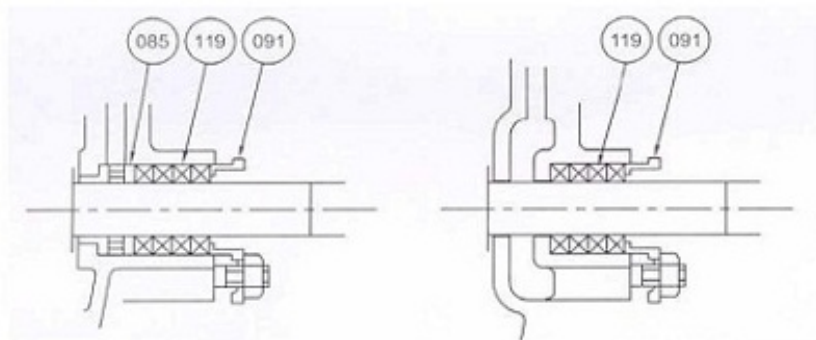

119	Gland Packing	Non-Asbestos	4 or 5
091	Gland	Bronze	1
085	Lantern Ring		
No.	Part Name	Material	Qty

119	Gland Packing	Non-Asbestos	4 or 5
091	Gland	Bronze	1
No.	Part Name	Material	Qty

207	Plug	Steel	1
111	Gland Packing	Non-Asbestos	4 or 5
107-2	Casing Ring	Bronze	1
107-1	Casing Ring		
095	Stay	Steel	1
056	Ball Bearing	-	2
053	Bearing Cover	Cast Iron	1
051	Bearing Housing		
048	Impeller Nut	Brass	
031	Shaft	Stainless Steel	
021	Impeller	Bronze	
011	Casing Cover	Cast Iron	
001	Casing		
No.	Part Name	Material	Qty