

# Technical data

Pump name

150x125 CNGA 5 18.5

Customer	Date	2021-05-14	Company
Contact	Item no.		Issued by
Phone	Project		Phone
E-mail	Project ID		E-mail

## Requested data

1	Pump type	Horizontal Split Casing	Fluid	Water
2	Number of pumps / Reserve	1 / 0	Liquid temperature	°C 20
3	Flow	m³/h	Kin. viscosity	mm²/s 1.005
4	Head	m	Vapour pressure	kPa 2.34
5	Geodetic head	m	PH value	
6	Inlet pressure (pin)	kPa 0	Density	kg/m³ 998.3
7	Available system NPSH		Solids	Weight % 0
8	Ambient temperature	°C 20		

## Pump

9	Pump name	150x125 CNGA 5 18.5	Frequency	Hz 50
10	Design	Horizontal Split Casing	Installation type	with base, motor
11	Manufacturer	EBARA	Impeller Diameter	Max. mm 274
12	Speed	rpm 1450		Designed mm 274
13	No. of Stage	1		Min. mm 227
14	Connection Suction side	JIS 16K	Flow	Operating m³/h
15	Connection Discharge side	JIS 16K		Max- m³/h 288
16	Max Working Pressure	kPa 1600		Min- m³/h 0
17	Shut-off head	kPa 267.82	Head	Operating m
18	Total weight	kg See the table of "Dimensions".		- (Qmax.) m 14.2
19	Shaft power	kW		- (Qmin.) m 27.3
20			Max. Shaft Power at max. impeller	kW 16.75
21	Required pump NPSH	m	Efficiency	%

## Materials

22	Casing	Cast iron	
23	Impeller	Bronze	
24	Shaft	316 Stainless steel	
25	Shaft sleeve	.	
26	Mechanical seal	.	
27	Ball bearing	.	

## Motor

28	Manufacturer	TECO	Insulation class	F
29	Type	180MC_B3_18.5_3_400	Phases	3~
30	Specific design	TEFC / 50 Hz / Pole pairs 2	Frame size	180 MC
31	Rated power	kW 18.5	Weight	kg 172
32	Number of poles	4	Electric voltage	V 400
33	Speed	rpm 1455	Electric current	A 34.5
34	Degree of protection	IP 55		
35				

## Remarks

# Performance curve

Pump name

150x125 CNGA 5 18.5

Customer	Date 2021-05-14	Company
Contact	Item no.	Issued by
Phone	Project	Phone
E-mail	Project ID	E-mail

## Requested data

1	Flow	m <sup>3</sup> /h	
2	Head	m	
3	Geodetic head	m	

## Pump

Operating Flow	m <sup>3</sup> /h	Frequency	Hz	50
Operating Head	m	Number of poles		4
Impeller Diameter Designed	mm	Speed	rpm	1450
	274			

Test standard: ISO 9906:2012 - Grade3B

Water; 20°C; 998.3kg/m<sup>3</sup>; 1.005mm<sup>2</sup>/s

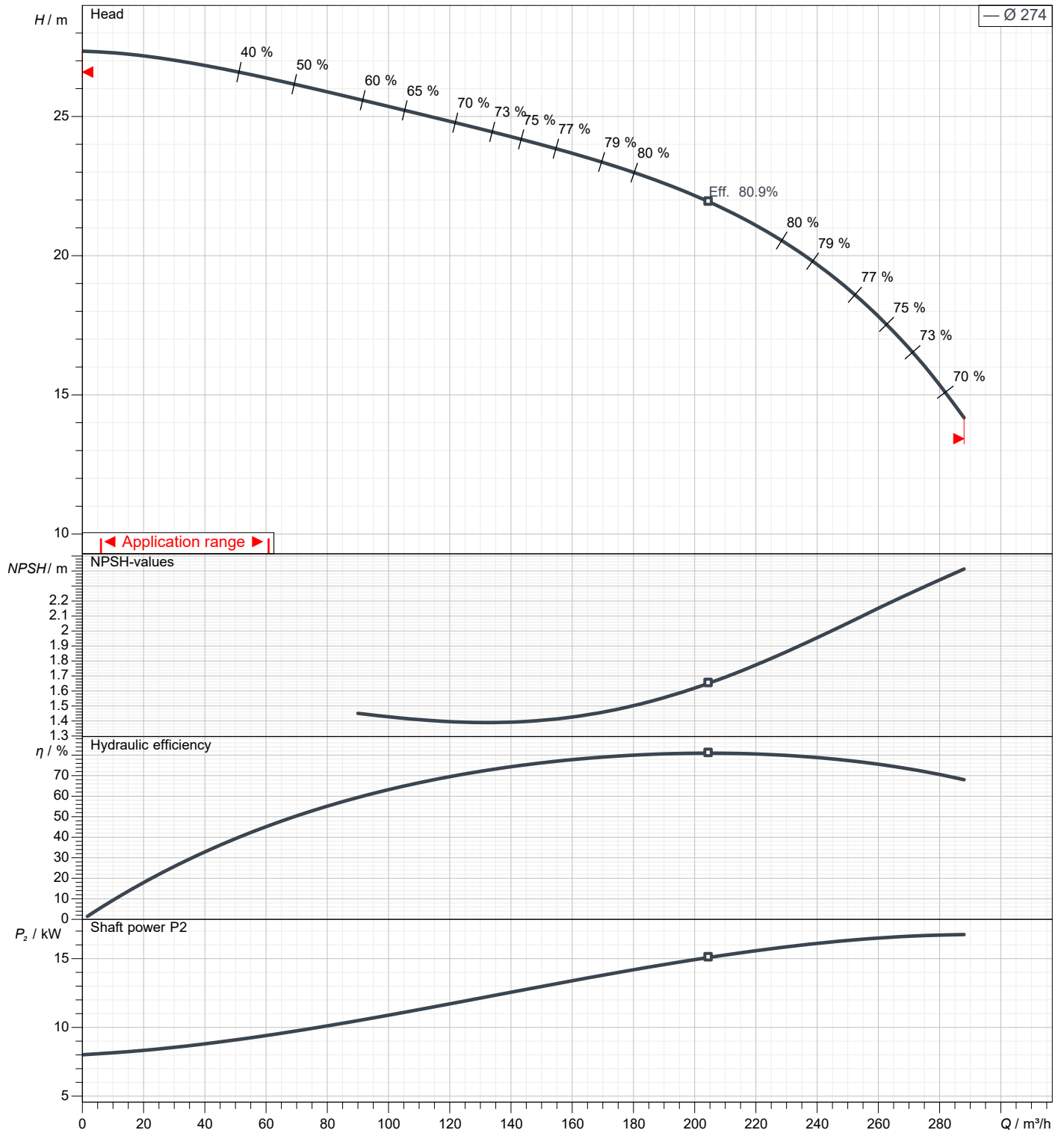

# Dimensions

Pump name 150x125 CNGA 5 18.5

Customer	Date 2021-05-14	Company
Contact	Item no.	Issued by
Phone	Project	Phone
E-mail	Project ID	E-mail

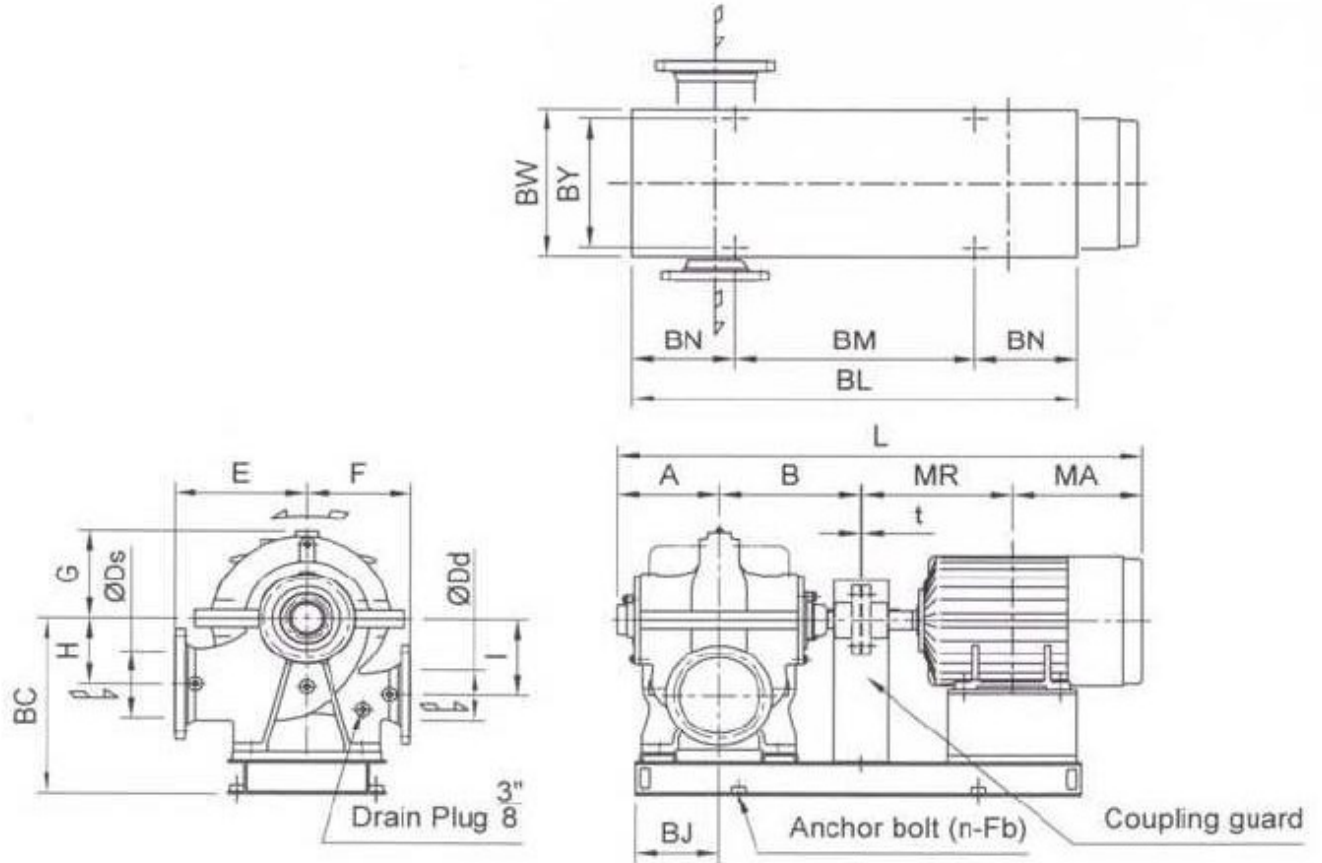

### Flange Dimension - Flange (JIS 16K RF)

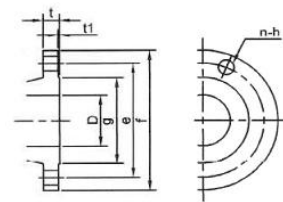

Total weight : 533 kg

Pump dimensions				Suction side		Discharge side	
mm				mm		mm	
A	262	H	190	D	150	D	125
B	395	l	190	e	260	e	225
BC	471	L	1332	f	305	f	270
BJ	210	MA	320.5	g	230	g	195
BL	1130	MR	351.5	h	25	h	23
BM	700	n	4 (Num)	n Num	8 (Num)	n Num	8 (Num)
BN	215	t	3	t	28	t	26
BW	450			t1	2	t1	2
BY	400						
Dd	125						
Ds	150						
E	330						
F	260						
Fb	M16						
G	224						

# (1/2) Construction

Pump name 150x125 CNGA 5 18.5

Customer	Date 2021-05-14	Company
Contact	Item no.	Issued by
Phone	Project	Phone
E-mail	Project ID	E-mail

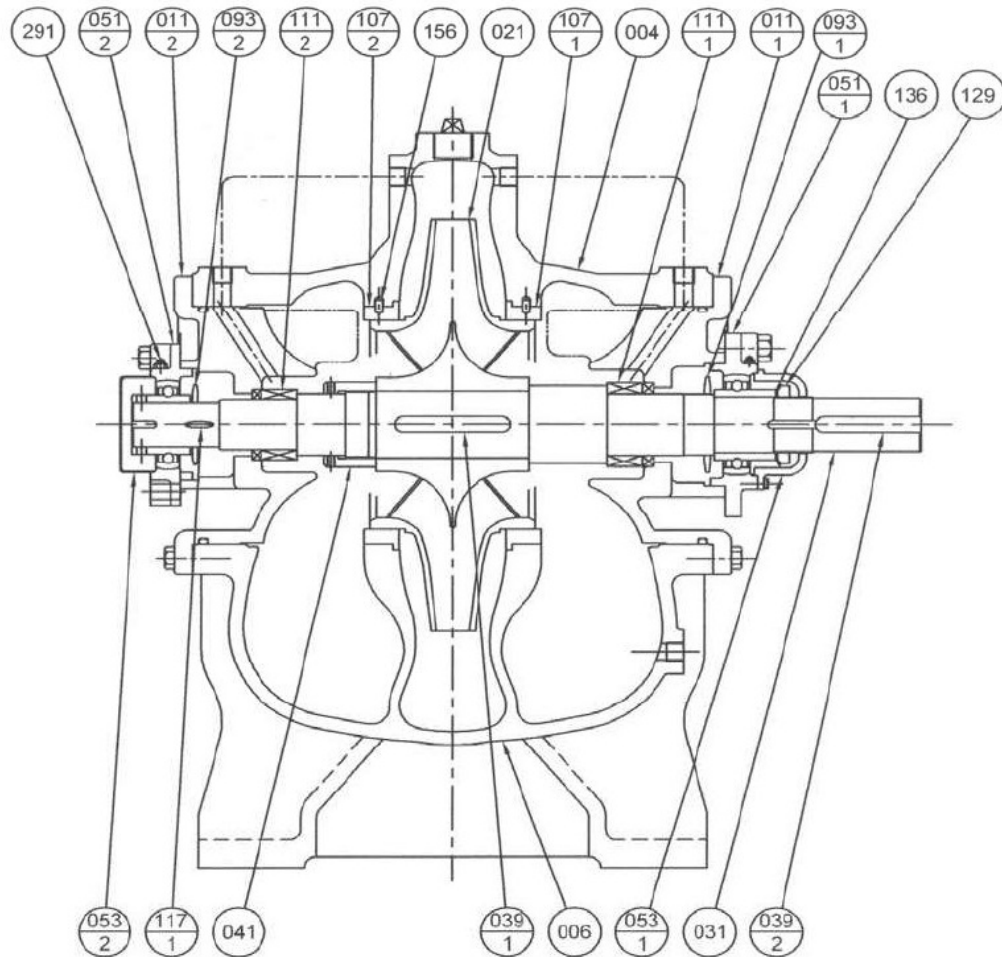

### Mechanical Seal Type (Standard)

051-2	Bearing Unit	FC200	1	291	Grease Nipple	C3604BD-F	2
051-1	Bearing Unit			156	Lock Pin	SUS304	
041	Impeller Nut	BC6		136	Bearing Washer	SS400	1
039-2	Coupling Key	S50C		129	Bearing Nut		
039-1	Impeller Key	316 Stainless		117-1	Gasket (Casing)	V#6500	
031	Shaft	Steel		111-2	Mechanical Seal	-	
021	Impeller	BC6		111-1	Mechanical Seal	-	
011-2	Side Cover	FC250		107	Casing Wear Ring	BC6	2
011-1	Side Cover			093-2	Deflector (CCP Side)	Rubber	1
006	Casing Lower Half			093-1	Deflector (CP Side)		
004	Casing Upper Half			053-2	Bearing Cover	FC200	
				053-1	Bearing Cover		
<b>No.</b>	<b>Part Name</b>	<b>Material</b>	<b>Qty</b>	<b>No.</b>	<b>Part Name</b>	<b>Material</b>	<b>Qty</b>

Customer	Date 2021-05-14	Company
Contact	Item no.	Issued by
Phone	Project	Phone
E-mail	Project ID	E-mail

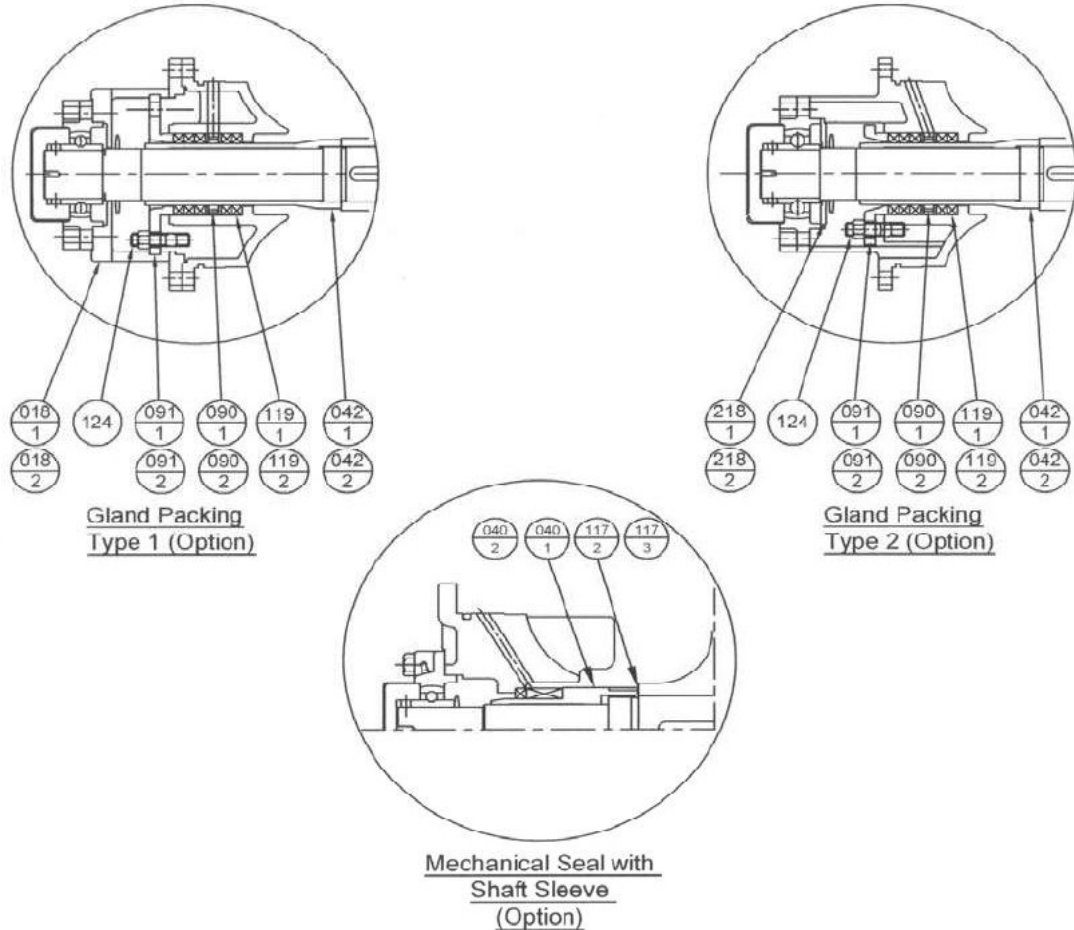

**Gland Packing Type 2 (Option)**

042-2	Shaft Sleeve (CCP Side)	BC6	1	119-2	Gland Packing (CCP Side)	Carbonised Fiber	5
042-1	Shaft Sleeve (CP Side)			119-1	Gland Packing (CP Side)	Carbonised Fiber	5
218-2	Bearing Cover Plate (CCP Side)	FC150	1	090-2	Lantern Ring (CCP Side)	BC6	1
218-1	Bearing Cover Plate (CP Side)			090-1	Lantern Ring (CP Side)		
124	Gland Bolt	C3604BD-F	4	091-2	Gland (CCP Side)		
				091-1	Gland (CP Side)		

**Gland Packing Type 1 (Option)**

042-2	Shaft Sleeve (CCP Side)	BC6	1	119-2	Gland Packing (CCP Side)	Carbonised Fiber	5
042-1	Shaft Sleeve (CP Side)			119-1	Gland Packing (CP Side)	Carbonised Fiber	5
018-2	Bearing Support (CCP Side)	FC200	1	090-2	Lantern Ring (CCP Side)	BC6	1
018-1	Bearing Support (CP Side)			090-1	Lantern Ring (CP Side)		
124	Gland Bolt	C3604BD-F	4	091-2	Gland (CCP Side)		
				091-1	Gland (CP Side)		

**Mechanical Seal with Shaft Sleeve Type (Option)**

040-2	Shaft Sleeve (CCP Side)	BC6	1	117-3	Sleeve Gasket (CCP Side)	V#6500	1
040-1	Shaft Sleeve (CP Side)	BC6		117-2	Sleeve Gasket (CP Side)	V#6500	
<b>No.</b>	<b>Part Name</b>	<b>Material</b>	<b>Qty</b>	<b>No.</b>	<b>Part Name</b>	<b>Material</b>	<b>Qty</b>