

Technical data

Pump name

80x65 FS2HA 5 15

Customer	Date	2021-05-06	Company
Contact	Item no.		Issued by
Phone	Project		Phone
E-mail	Project ID		E-mail

Requested data

1	Pump type	End Suction Volute Pump	Fluid	Water
2	Number of pumps / Reserve	1 / 0	Liquid temperature	°C 20
3	Flow	m³/h	Kin. viscosity	mm²/s 1.005
4	Head	m	Vapour pressure	bar 0.0234
5	Geodetic head	m	PH value	
6	Inlet pressure (pin)	bar 0	Density	kg/dm³ 0.9983
7	Available system NPSH		Solids	Weight % 0
8	Ambient temperature	°C 20		

Pump

9	Pump name	80x65 FS2HA 5 15	Frequency	Hz 50
10	Design	End Suction Volute Pump	Installation type	with base, motor
11	Manufacturer	EBARA	Impeller Diameter	Max. mm 215
12	Speed	rpm 2900		Designed mm 215
13	No. of Stage	1		Min. mm 180
14	Connection Suction side	JIS 10K	Flow	Operating m³/h
15	Connection Discharge side	JIS 10K		Max- m³/h 91.2
16	Max Working Pressure	bar 10		Min- m³/h 24
17	Shut-off head	bar 6.28	Head	Operating m
18	Total weight	kg See the table of "Dimensions".		- (Qmax.) m 34.4
19	Shaft power	kW		- (Qmin.) m 63.1
20			Max. Shaft Power at max. impeller	kW 13.93
21	Required pump NPSH	m	Efficiency	%

Materials

22	Casing	Cast iron	M.S.mating ring	Ceramic
23	Impeller	Bronze	M.S.seal ring	Carbon
24	Shaft	403 Stainless steel		
25	Casing ring	Bronze		
26	Ball bearing	.		
27	Mechanical seal	.		

Motor

28	Manufacturer	TECO	Insulation class	F
29	Type	160M_B3_15_3_400	Phases	3~
30	Specific design	TEFC / 50 Hz / Pole pairs 1	Frame size	160 M_15
31	Rated power	kW 15	Weight	kg 122
32	Number of poles	2	Electric voltage	V 400
33	Speed	rpm 2925	Electric current	A 26.2
34	Degree of protection	IP 55		
35				

Remarks

Performance curve

Pump name

80x65 FS2HA 5 15

Customer	Date	2021-05-06	Company
Contact	Item no.		Issued by
Phone	Project		Phone
E-mail	Project ID		E-mail

Requested data

1	Flow	m ³ /h	
2	Head	m	
3	Geodetic head	m	

Pump

Operating Flow	m ³ /h		Frequency	Hz	50
Operating Head	m		Number of poles		2
ImpellerDiameter Designed	mm	215	Speed	rpm	2900

Test standard: ISO 9906:2012 - Grade3B

Water; 20°C; 0.9983kg/dm³; 1.005mm²/s

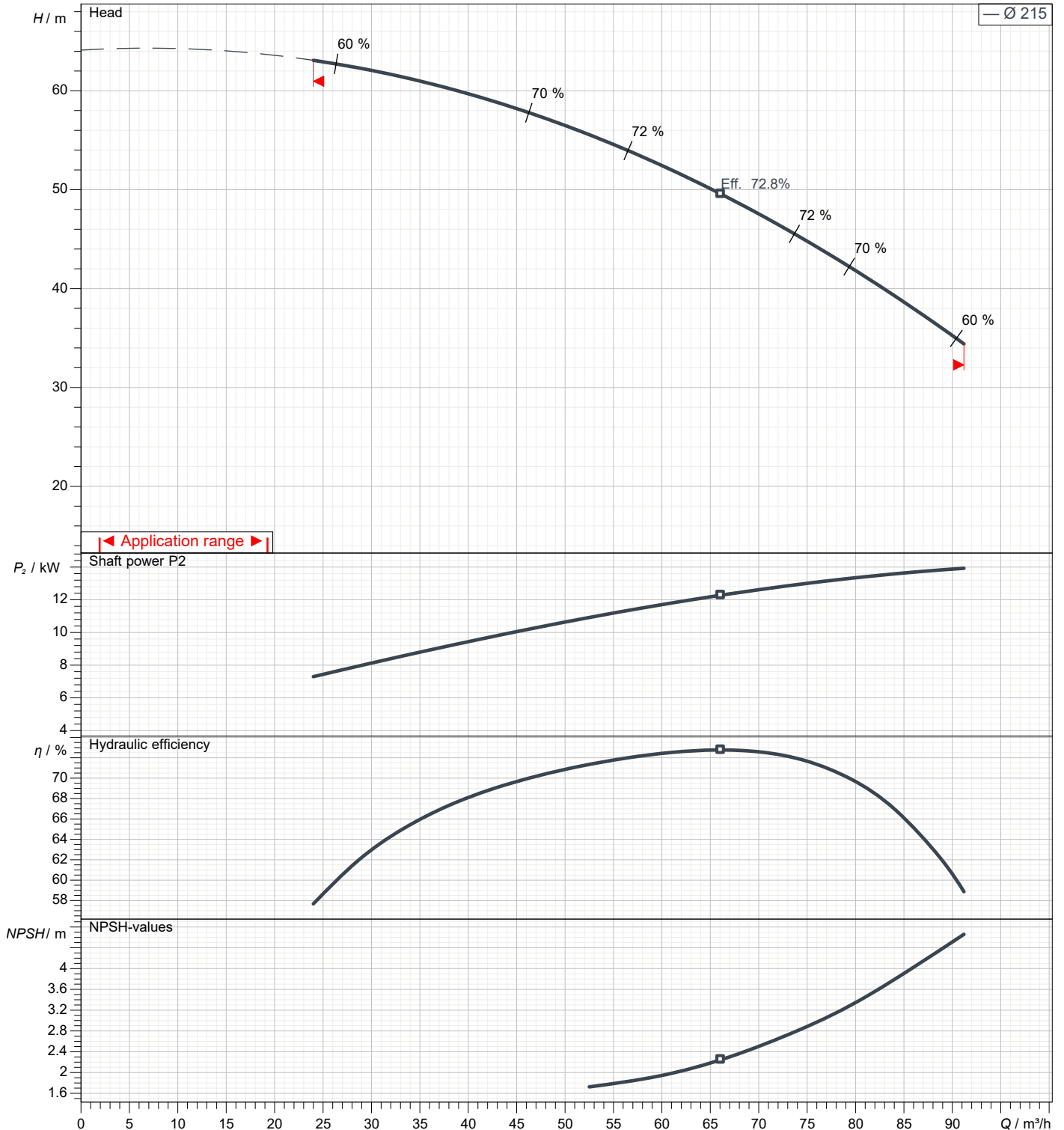

Dimensions

Pump name 80x65 FS2HA 5 15

Customer	Date 2021-05-06	Company
Contact	Item no.	Issued by
Phone	Project	Phone
E-mail	Project ID	E-mail

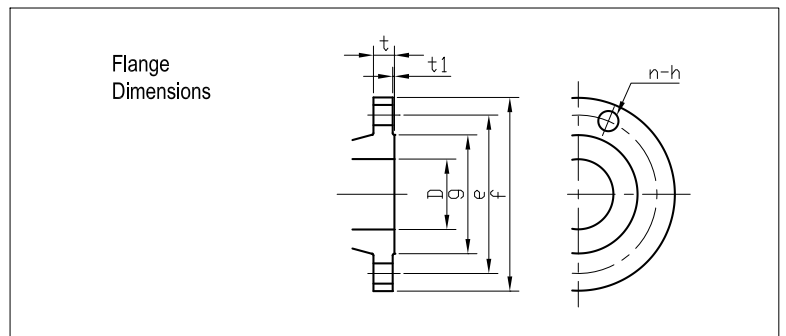
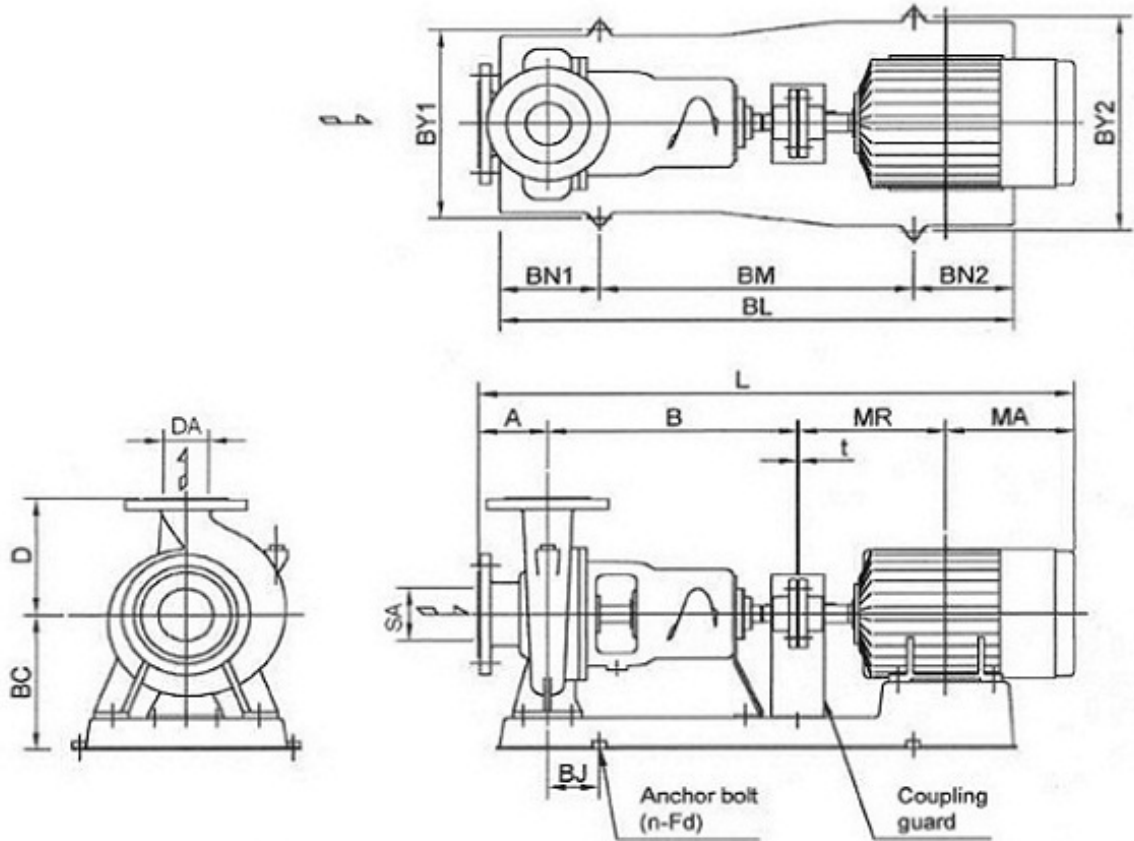

Total weight : 222 kg

Pump dimensions				mm		Suction side		mm		Discharge side		mm	
A	100	MR	323	D	80	D	65						
B	360	n	4 (Num)	e	150	e	140						
BC	250	SA	80	f	185	f	175						
BJ	98	t	3	g	126	g	116						
BL	960			h	19	h	19						
BM	600			n Num	8	n Num	4						
BN1	180			t	22	t	22						
BN2	180			t1	2	t1	2						
BY1	400												
BY2	400												
D	200												
DA	65												
Fd	M16												
L	1071												
MA	285												

(1/2)

Construction

Pump name 80x65 FS2HA 5 15

Customer	Date 2021-05-06	Company
Contact	Item no.	Issued by
Phone	Project	Phone
E-mail	Project ID	E-mail

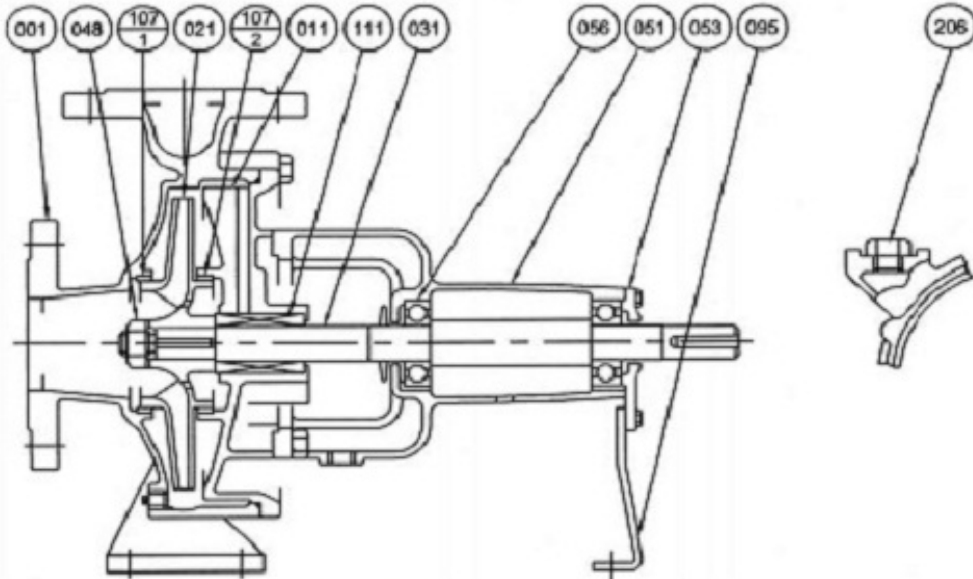

Model FH

50x40 FSHA; 65x50 FSHA, FSJA;
 80x65 FSGA, FSHA, FSJA, FSKA;
 100x80 FSGA, FSHA, FSJA;
 125x100 FSKA

Model EA

100x65 FSKA; 100x80 FSGCA, FSHCA;
 125x100 FSJCA, FSLA;
 150x100 FSKA, FSNA;
 150x125 FSHA, FSJA, FSKA, FSLA;
 200x150 FSHA, FSJA, FSKA, FSLA, FSNA;
 250x200 FSLA, FSNA

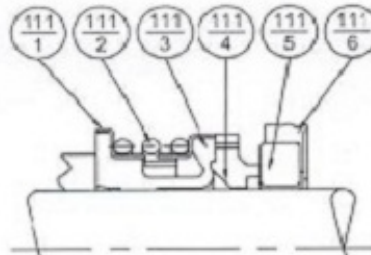
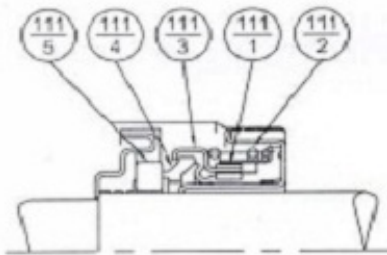

111-5	Mating Ring	Ceramic	1
111-4	Seal Ring	Carbon	
111-3	Friction Ring	NBR	
111-2	Coil Spring	Stainless Steel	
111-1	Spring Holder		
No.	Part Name	Material	Qty

111-6	Cup Gasket	NBR	1
111-5	Mating Ring	Ceramic	
111-4	Seal Ring	Carbon	
111-3	Bellows	NBR	
111-2	Spring	Stainless Steel	
111-1	Spring Holder		
No.	Part Name	Material	Qty

207	Plug	Steel	1
111	Mechanical Seal	-	
107-2	Casing Ring	Bronze	1
107-1	Casing Ring		
095	Stay	Steel	1
056	Ball Bearing	-	2
053	Bearing Cover	Cast Iron	1
051	Bearing Housing		
048	Impeller Nut	Brass	1
031	Shaft	Stainless Steel	
021	Impeller	Bronze	
011	Casing Cover	Cast Iron	
001	Casing		
No.	Part Name	Material	Qty

(2/2)

Construction

Pump name 80x65 FS2HA 5 15

Customer	Date 2021-05-06	Company
Contact	Item no.	Issued by
Phone	Project	Phone
E-mail	Project ID	E-mail

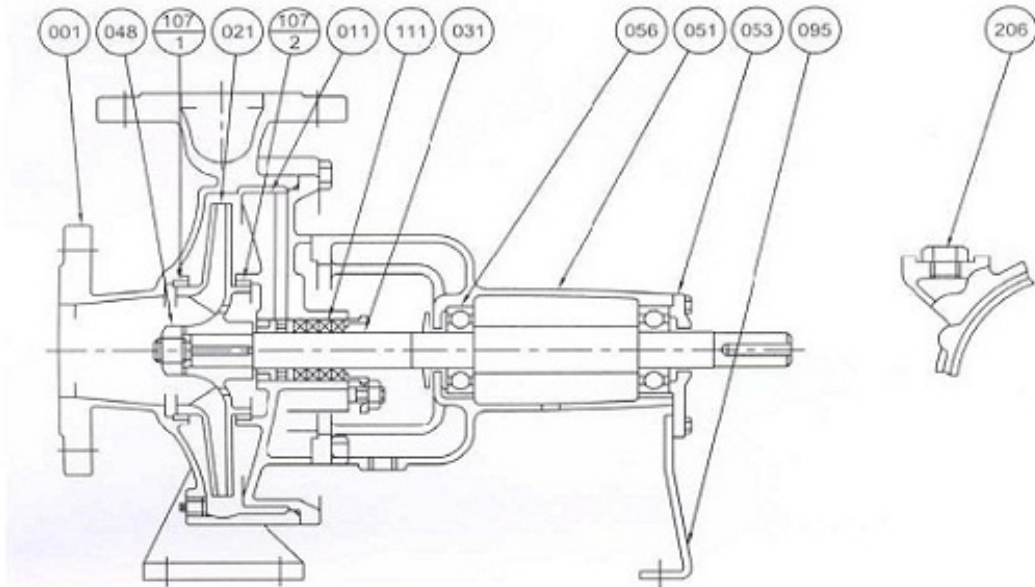

With Lantern Ring

50x40 FSHA; 65x50 FSHA, FSJA;
 80x65 FSGA, FSHA;
 100x80 FSGA; 125x100 FSLA;
 150x100 FSKA, FSNA;
 150x125 FSKA, FSLA;
 200x150 FSJA, FSLA, FSNA;
 250x200 FSLA, FSNA

Without Lantern Ring

80x65 FSJA, FSKA;
 100x65 FSKA;
 100x80 FSHA, FSJA, FSGCA, FSHCA;
 125x100 FSJCA, FSKA;
 150x125 FSHA, FSJA;
 200x150 FSHA, FSKA;

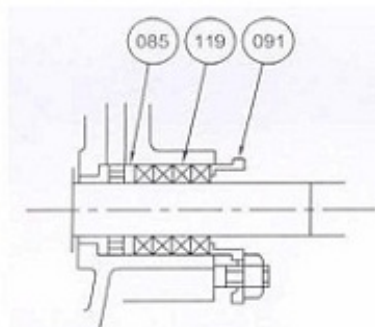

119	Gland Packing	Non-Asbestos	4 or 5
091	Gland	Bronze	1
085	Lantern Ring		
No.	Part Name	Material	Qty

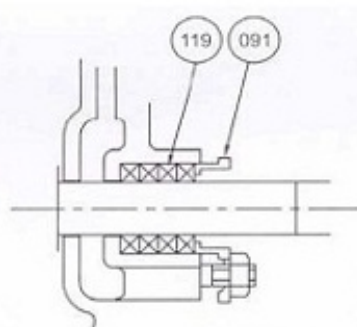

119	Gland Packing	Non-Asbestos	4 or 5
091	Gland	Bronze	1
No.	Part Name	Material	Qty

207	Plug	Steel	1
111	Gland Packing	Non-Asbestos	4 or 5
107-2	Casing Ring	Bronze	1
107-1	Casing Ring		
095	Stay	Steel	1
056	Ball Bearing	-	2
053	Bearing Cover	Cast Iron	1
051	Bearing Housing		
048	Impeller Nut	Brass	
031	Shaft	Stainless Steel	
021	Impeller	Bronze	
011	Casing Cover	Cast Iron	
001	Casing		
No.	Part Name	Material	Qty