

Technical data

Pump name

GS 50-315 /75

Customer	Date	2021-05-14	Company
Contact	Item no.		Issued by
Phone	Project		Phone
E-mail	Project ID		E-mail

Requested data

1	Pump type	End Suction Volute Pump	Fluid	Water
2	Number of pumps / Reserve	1 / 0	Liquid temperature	°C 20
3	Flow	m³/h	Kin. viscosity	mm²/s 1.005
4	Head	m	Vapour pressure	kPa 2.34
5	Geodetic head	m	PH value	
6	Inlet pressure (pin)	kPa 0	Density	kg/m³ 998.3
7	Available system NPSH		Solids	Weight % 0
8	Ambient temperature	°C 20		

Pump

9	Pump name	GS 50-315 /75	Frequency	Hz 50
10	Design	End Suction Volute Pump	Installation type	with ISO base, motor
11	Manufacturer	EBARA	Impeller Diameter	Max. mm 324
12	Speed	rpm 2900		Designed mm 324
13	No. of Stage	1		Min. mm 277
14	Connection	Suction side	Flow	Operating m³/h
15	Connection	Discharge side		Max- m³/h 140
16	Max Working Pressure	kPa 1600		Min- m³/h 15.8
17	Shut-off head	kPa 1514.93	Head	Operating m
18	Total weight	kg See the table of "Dimensions".		- (Qmax.) m 109.8
19	Shaft power	kW		- (Qmin.) m 154.0
20			Max. Shaft Power at max. impeller	kW 65.83
21	Required pump NPSH	m	Efficiency	%

Materials

22	Casing	FC250	
23	Impeller	FC200	
24	Shaft	SUS431eq.	
25	Case wear ring	CAC406	
26	O-ring	NBR	
27	Mechanical Seal	SiC/Carbon/FKM	

Motor

28	Manufacturer	TECHTOP	Insulation class	F
29	Type	280S_75_3_400	Phases	3~
30	Specific design	TEFC/B3/IE3/TC / 50 Hz / Pole pairs 1	Frame size	280S_2P
31	Rated power	kW 75	Weight	kg 734
32	Number of poles	2	Electric voltage	V 400
33	Speed	rpm 2940	Electric current	A 124
34	Degree of protection	IP55		
35				

Remarks

Performance curve

Pump name

GS 50-315 /75

Customer	Date	2021-05-14	Company
Contact	Item no.		Issued by
Phone	Project		Phone
E-mail	Project ID		E-mail

Requested data

1	Flow	m ³ /h	
2	Head	m	
3	Geodetic head	m	

Pump

Operating Flow	m ³ /h		Frequency	Hz	50
Operating Head	m		Number of poles		2
Impeller Diameter Designed	mm	324	Speed	rpm	2900

Test standard: ISO 9906:2012 - Grade3B

Water; 20°C; 998.3kg/m³; 1mm²/s

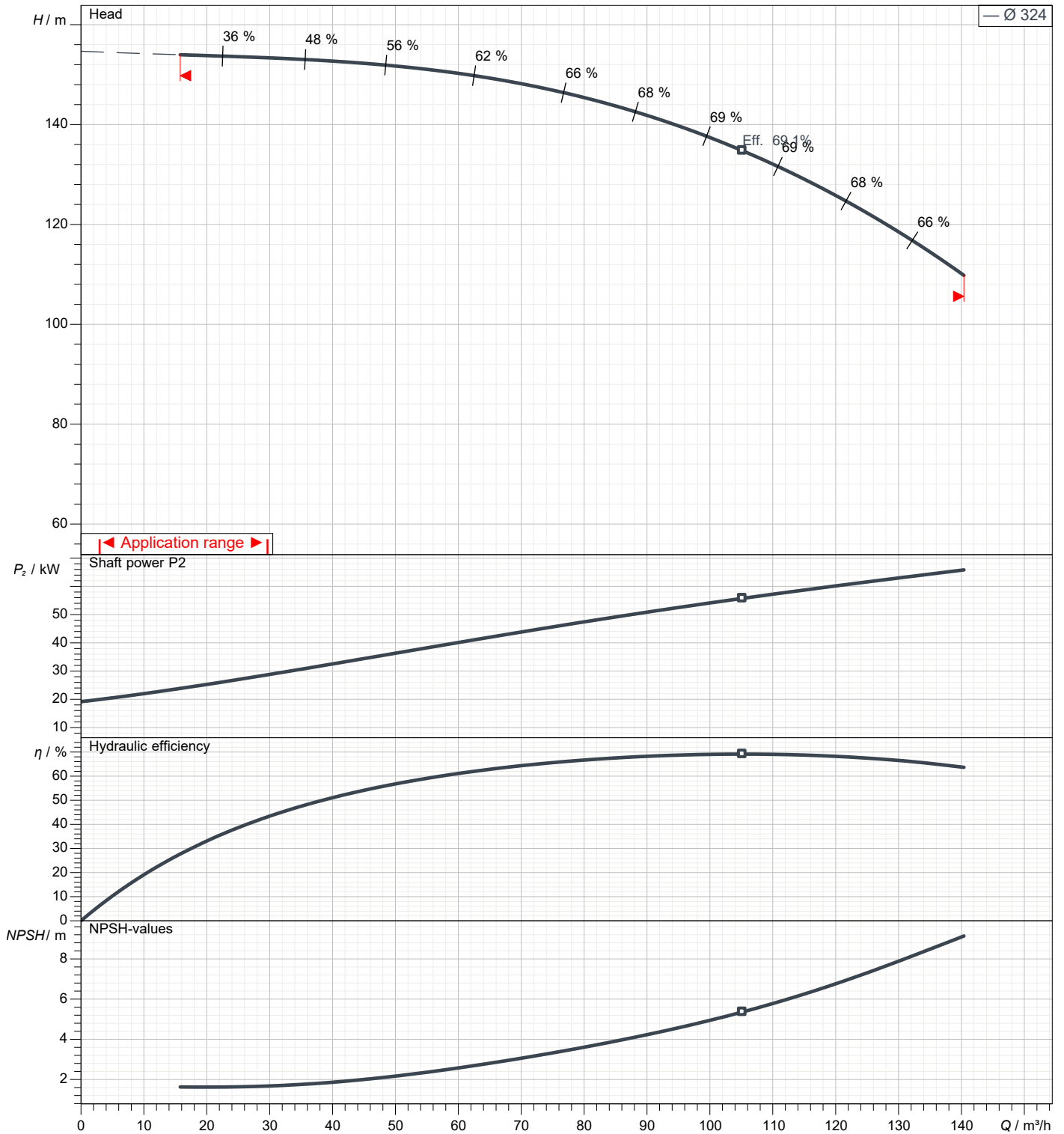

Dimensions

Pump name GS 50-315 /75

Customer	Date 2021-05-14	Company
Contact	Item no.	Issued by
Phone	Project	Phone
E-mail	Project ID	E-mail

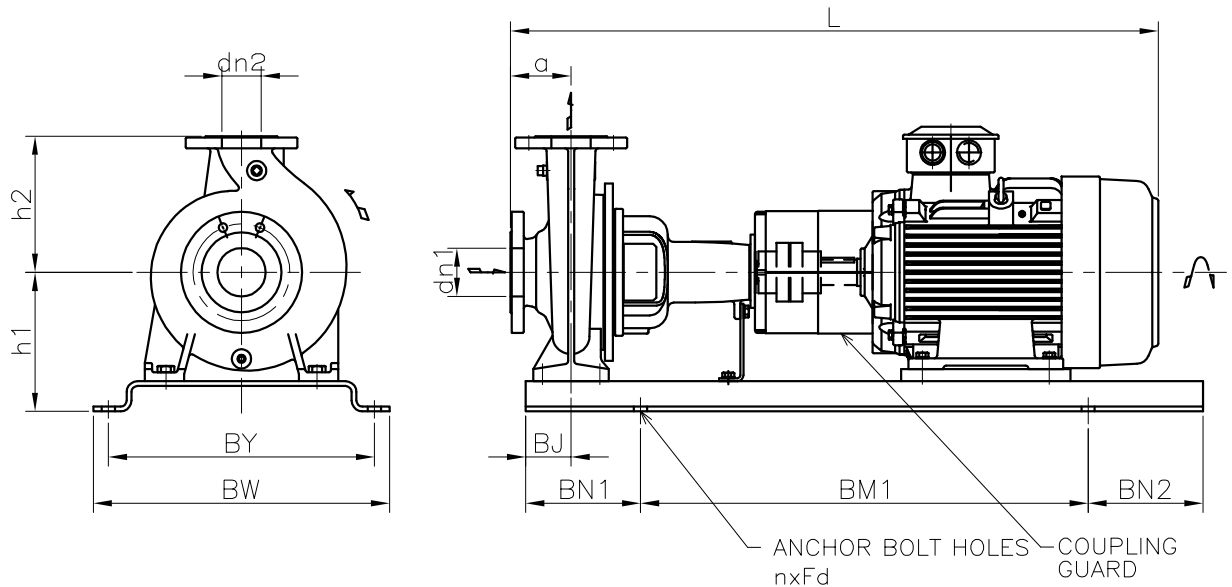

This base is not necessary to grout.
Special base can be provided for grouting.



Total weight : 797 kg

Pump dimensions		mm		Suction side		mm		Discharge side		mm	
a	125										
dn1	65										
dn2	50										
h1	225										
h2	280										
L	1579										

Construction

Pump name GS 50-315 /75

Customer	Date 2021-05-14	Company
Contact	Item no.	Issued by
Phone	Project	Phone
E-mail	Project ID	E-mail