

CARATTERISTICHE COSTRUTTIVE / CONSTRUCTION FEATURES
CARACTERÍSTICAS CONSTRUCTIVAS / CARACTÉRISTIQUES D'EXÉCUTION

Corpo pompa	ghisa
Pump body	cast iron
Cuerpo bomba	fundición
Corps de pompe	fonte
Supporto motore	ghisa
Motor bracket	cast iron
Soporte motor	fundición
Support moteur	fonte
Girante	ghisa, bronzo o acciaio
Impeller	cast iron, bronze or stainless steel
Rodete	fundición, bronce o acero
Turbine	fonte, bronze ou acier
Tenuta meccanica	ceramica-grafite
Mechanical seal	ceramic-graphite
Sello mecánico	cerámica-grafito
Garniture mécanique	céramique-graphite
Albero motore	acciaio AISI 316
Motor shaft	stainless steel AISI 316
Eje motor	acero AISI 316
Arbre moteur	acier AISI 316
Temperatura del liquido	
Liquid temperature	-10 ÷ +90 °C
Temperatura del liquido	
Température du liquide	
Pressione di esercizio	
Operating pressure	max 10 bar
Presión de trabajo	
Pression de fonctionnement	
MOTORE / MOTOR / MOTOR / MOTEUR	
Motore 2 poli a induzione	
2 pole induction motor	3~ 230/400V-50Hz
Motor de 2 polos a inducción	1~ 230V-50Hz
Moteur à induction à 2 pôles	
Classe di isolamento	
Insulation class	F
Clase de aislamiento	
Classe d'isolation	
Grado di protezione	
Protection degree	IP55
Grado de protección	
Protection	



Pompe centrifughe monoblocco ad asse orizzontale costruite secondo le norme EN 733; trovano vasto utilizzo nell'alimentazione idrica, negli impianti di pressurizzazione e antincendio, raffreddamento, riscaldamento, irrigazione, applicazioni agricole e industriali; come standard vengono fornite di controflangia.

Monobloc horizontal centrifugal pumps, constructed to EN 733 standards; widely used in water supplies, pressurisation and fire-fighting systems, cooling, heating, irrigation, industrial and agricultural applications; standard supply with counter-flange.

Bombas centrifugas monobloque de eje horizontal fabricadas según las normas EN 733; se utilizan en gran parte en la alimentación hídrica, en las instalaciones de presurización y antiincendio, enfriamiento, calefacción, riego, aplicaciones agrícolas e industriales; según el estándar se suministran con contrabrida.

Pompes centrifuges monobloc à axe horizontal, fabriquées conformément aux normes EN 733. Elles trouvent une ample utilisation dans l'approvisionnement d'eau, dans les installations de pressurisation et anti-incendie, refroidissement, chauffage, irrigation, applications agricoles et industrielles; fournies de série avec contre-bride.

65-250

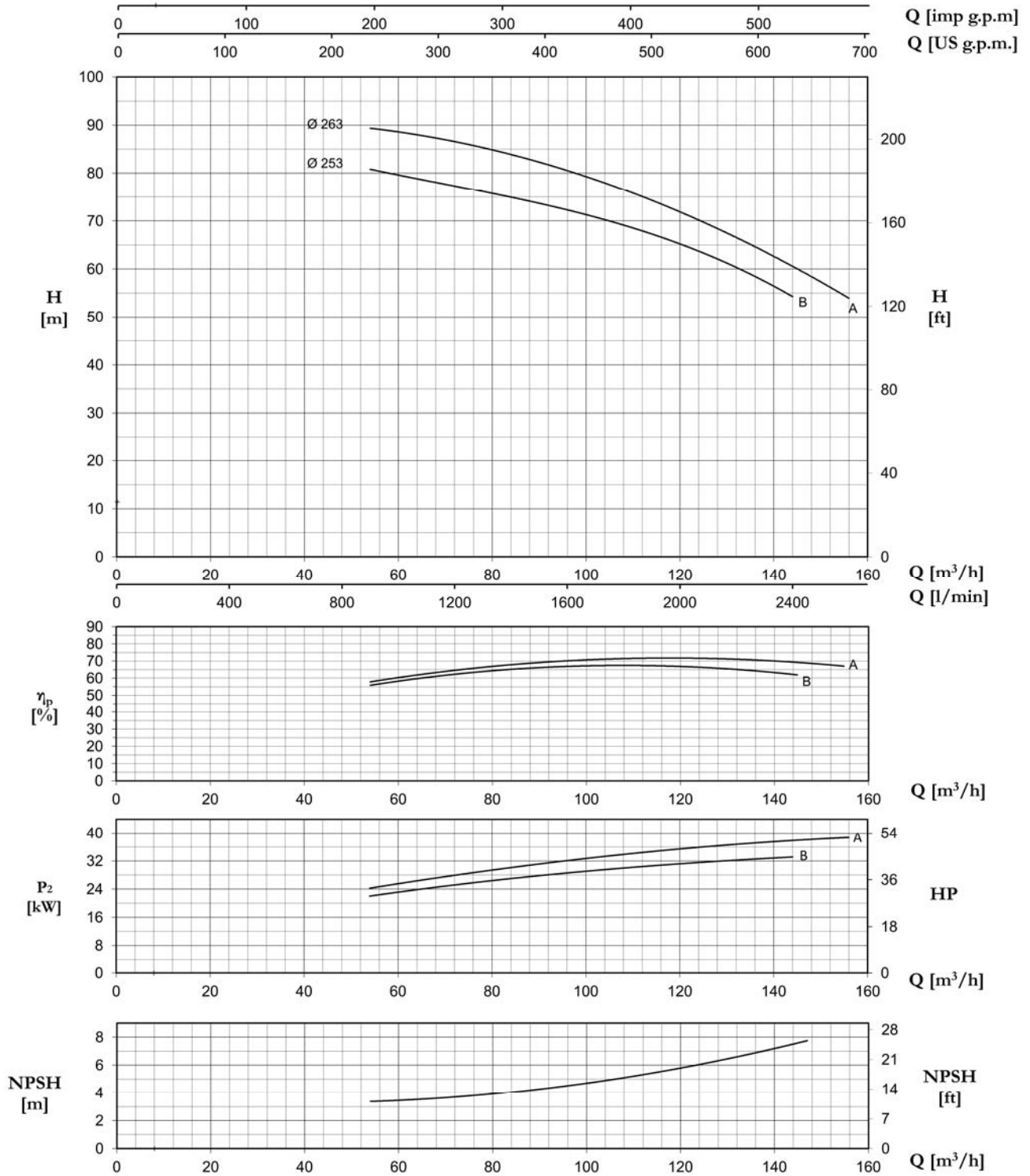

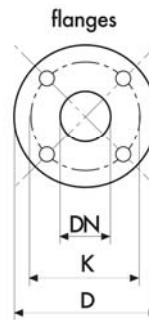
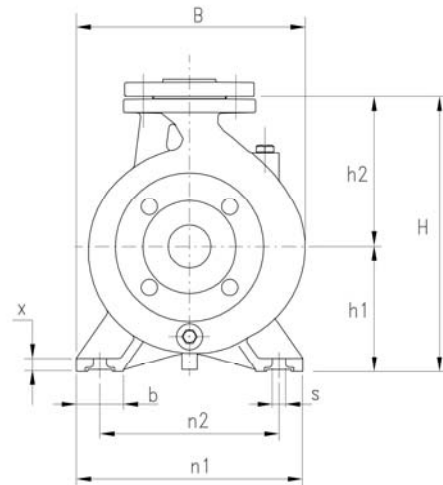
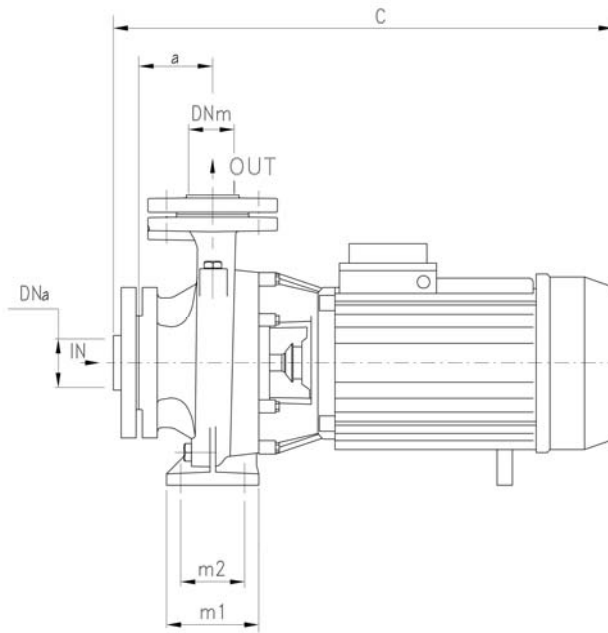

TYPE	P2		P1 (kW)	Q (m³/h - l/min)															
				A															
				3~															
3~	(HP)	(kW)	3~	H (m)															
				3x400 V 50 Hz	0	54	60	66	72	78	84	96	108	120	132	144	156		
65-250 B	40	30	37,8	63,5	81,0	79,5	78,5	77,3	76,0	74,5	73,0	69,3	65,0	60,0	54,5	48,5	-		
65-250 A	50	37	45	74,5	90,0	89,5	88,5	87,5	86,5	85,5	84,0	80,5	76,5	72,0	66,5	60,5	54,0		

CM EN 733 ~ 2900 r.p.m.



DIMENSIONS (mm)				
DN	D	K	holes	
			n°	Ø
32	140	100	4	18
40	150	110	4	18
50	165	125	4	18
65	185	145	4	18
80	200	160	8	18
100	220	180	8	18
125	250	210	8	18

TYPE	TRUCK		CONTAINER	
	PALLET (cm)	N° pumps	PALLET (cm)	N° pumps
32-160	80X120X155	24	80X120X190	30
32-200 C		24	80X120X180	24
32-200 A/B	100X120X140	18	100X120X185	24
32-250 A	85X110X120	6	85X110X170	9
32-250 B/C	80X120X120	6	80X120X170	9
40-125	80X120X155	24	80X120X190	30
40-160	80X120X155	24	80X120X190	30
40-200	100X120X140	18	100X120X185	24
40-250 A	85X110X120	6	85X110X170	9
40-250 B/C	80X120X120	6	80X120X170	9
50-125		24	80X120X180	24
50-160	100X120X140	18	100X120X185	24
50-200 A	85X110X120	6	85X110X170	9
50-200 B/C	80X120X120	6	80X120X170	9
50-250	80X120X120	6	80X120X170	9
65-125	100X120X140	18	100X120X185	24
65-160	85X110X120	6	85X110X170	9
65-200	85X110X120	6	85X110X170	9
65-250	85X110X130	4	85X110X190	6
80-160	85X110X120	6	85X110X170	9
80-200	85X110X130	4	85X110X190	6

TYPE	DIMENSIONS (mm)																		
	DNa	DNm	a	h1	h2	m1	m2	n1	n2	b	x	s	C	B	H			I	L
32-160 C	50	32	80	132	160	100	70	240	190	50	12	14	490	240	292	520	260	355	38
32-160 B	50	32	80	132	160	100	70	240	190	50	12	14	490	240	292	520	260	355	39
32-160 A	50	32	80	132	160	100	70	240	190	50	12	14	490	240	292	520	260	355	42
32-200 C	50	32	80	160	180	100	70	240	190	50	12	14	505	268	340	530	305	400	51.5
32-200 B1	50	32	80	160	180	100	70	240	190	50	12	14	520	268	340	615	310	460	61
32-200 B	50	32	80	160	180	100	70	240	190	50	12	14	565	268	340	615	310	460	63
32-200 A1	50	32	80	160	180	100	70	240	190	50	12	14	520	268	340	615	310	460	67
32-200 A	50	32	80	160	180	100	70	240	190	50	12	14	565	268	340	615	310	460	69
32-250 C	50	32	100	180	225	125	95	320	250	65	12	14	625	305	405	665	335	535	83
32-250 B	50	32	100	180	225	125	95	320	250	65	14	14	625	305	405	665	335	535	90
32-250 A1	50	32	100	180	225	125	95	320	250	65	14	14	625	305	405	665	335	535	95
32-250 A	50	32	100	180	225	125	95	320	250	65	14	14	695	305	405	735	355	535	120
40-125 C	65	40	80	112	140	100	70	210	160	50	12	14	495	220	252	520	260	355	36
40-125 B	65	40	80	112	140	100	70	210	160	50	12	14	495	220	252	520	260	355	37
40-125 A	65	40	80	112	140	100	70	210	160	50	12	14	495	220	252	520	260	355	40
40-160 B	65	40	80	132	160	100	70	240	190	50	12	14	500	245	292	520	260	355	47
40-160 A	65	40	80	132	160	100	70	240	190	50	15	14	500	245	292	520	260	355	50
40-200 B1	65	40	80	132	160	100	70	240	190	50	15	14	545	273	340	615	310	460	63
40-200 B	65	40	100	160	180	100	70	265	212	50	15	14	590	273	340	615	310	460	65
40-200 A1	65	40	80	132	160	100	70	240	190	50	15	14	545	273	340	615	310	460	69
40-200 A	65	40	100	160	180	100	70	265	212	50	15	14	590	273	340	615	310	460	71
40-250 C	65	40	100	180	225	125	95	320	250	65	15	14	630	322	405	665	335	535	84
40-250 B	65	40	100	180	225	125	95	320	250	65	15	14	630	322	405	665	335	535	91
40-250 A1	65	40	100	180	225	125	95	320	250	65	15	14	630	322	405	665	335	535	96
40-250 A	65	40	100	180	225	125	95	320	250	65	15	14	700	322	405	735	355	535	121
50-125 B	65	50	100	132	160	100	70	240	190	50	12	14	525	250	292	520	260	355	47
50-125 A	65	50	100	132	160	100	70	240	190	50	12	14	525	250	292	520	260	355	50
50-160 B1	65	50	100	160	180	100	70	265	212	50	12	14	545	270	340	615	310	460	63
50-160 B	65	50	100	160	180	100	70	265	212	50	12	14	590	270	340	615	310	460	65
50-160 A1	65	50	100	160	180	100	70	265	212	50	12	14	545	270	340	615	310	460	69
50-160 A	65	50	100	160	180	100	70	265	212	50	12	14	590	270	340	615	310	460	71
50-200 C	65	50	100	160	200	100	70	265	212	50	12	14	635	290	360	665	335	535	82
50-200 B	65	50	100	160	200	100	70	265	212	50	12	14	635	290	360	665	335	535	89
50-200 A1	65	50	100	160	200	100	70	265	212	50	12	14	635	290	360	665	335	535	94
50-200 A	65	50	100	160	200	100	70	265	212	50	12	14	705	290	360	735	355	535	122
50-250 C	65	50	100	180	225	125	95	320	250	65	14	14	705	332	405	735	355	535	125
50-250 B	65	50	100	180	225	125	95	320	250	65	14	14	750	332	405	815	355	535	140
50-250 A	65	50	100	180	225	125	95	320	250	65	14	14	750	332	405	815	355	535	149
65-125 B1	80	65	100	160	180	125	95	280	212	65	14	14	560	280	340	615	310	460	62
65-125 B	80	65	100	160	180	125	95	280	212	65	14	14	605	280	340	615	310	460	64
65-125 A1	80	65	100	160	180	125	95	280	212	65	14	14	560	280	340	615	310	460	68
65-125 A	80	65	100	160	180	125	95	280	212	65	14	14	605	280	340	615	310	460	70
65-160 C	80	65	100	160	200	125	95	280	212	65	14	14	635	290	360	665	335	535	84
65-160 B	80	65	100	160	200	125	95	280	212	65	14	14	635	290	360	665	335	535	90
65-160 A1	80	65	100	160	200	125	95	280	212	65	14	14	635	290	360	665	355	535	95
65-160 A	80	65	100	160	200	125	95	280	212	65	14	14	705	290	360	735	355	535	120
65-200 C1	80	65	100	180	225	125	95	320	250	65	14	14	675	330	405	735	355	535	92
65-200 C	80	65	100	180	225	125	95	320	250	65	14	14	705	330	405	735	355	535	122
65-200 B	80	65	100	180	225	125	95	320	250	65	14	14	750	330	405	815	355	535	138
65-200 A	80	65	100	180	225	125	95	320	250	65	14	14	750	330	405	815	355	535	148
65-250 B	80	65	100	200	250	160	120	360	280	80	16	19	850	370	450	850	380	490	239
65-250 A	80	65	100	200	250	160	120	360	280	80	16	19	850	370	450	850	380	490	253
80-160 E	100	80	125	180	225	125	95	320	250	65	14	14	665	330	405	665	335	535	92
80-160 D	100	80	125	180	225	125	95	320	250	65	14	14	665	330	405	665	335	535	98.5
80-160 C1	100	80	125	180	225	125	95	320	250	65	14	14	665	330	405	665	335	535	104
80-160 C	100	80	125	180	225	125	95	320	250	65	14	14	735	330	405	735	355	535	129
80-160 B	100	80	125	180	225	125	95	320	250	65	14	14	780	330	405	815	355	535	143
80-160 A	100	80	125	180	225	125	95	320	250	65	14	14	780	330	405	815	355	535	152
80-200 B	100	80	125	180	250	125	95	345	280	65	16	14	840	355	405	850	380	490	184
80-200 A	100	80	125	180	250	125	95	345	280	65	16	14	840	355	405	850	380	490	216
100-160 B	125	100	125	200	280	160	120	360	280	80	18	18	842	390	480	850	420	570	198
100-160 A	125	100	125	200	280	160	120	360	280	80	18	18	842	390	480	850	420	570	230