

**Customer**

## Technical data

### Glanded monobloc pump Atmos BST 40/200-5.5/2-V2

Project name: Untitled project 2024-07-25 06:23:36.493

Project ID  
Installation location  
Customer pos. No.

Date: 2024-07-25

#### Duty chart

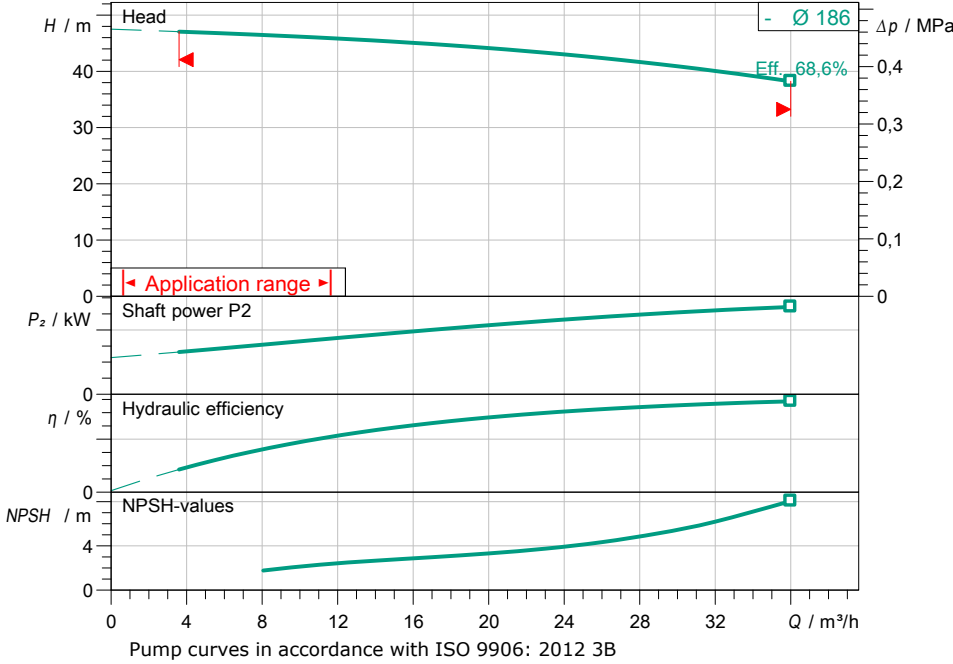

#### Requested data

Flow  
Head  
Media: Water 100 %  
Fluid temperature: 20,00 °C  
Density: 998,30 kg/m<sup>3</sup>  
Kin. viscosity: 1,00 mm<sup>2</sup>/s

#### Hydraulic data (Duty point)

Flow  
Head  
Shaft power P2  
Hydraulic efficiency  
NPSH  
Impeller size: 186

#### Product data

Glanded monobloc pump  
Atmos BST 40/200-5.5/2-V2  
Max. operating pressure: 1 MPa  
Fluid temperature: -20 °C ... +120 °C  
Max. ambient temperature: 50 °C  
Minimum efficiency index (MEI): ≥ 0.4

#### Motordata per Motor/Pump

Motor efficiency level: IE3  
Mains connection: 3~ 400 V / 50 Hz  
Permitted voltage tolerance: + -6 %  
Max. speed: 2900 1/min  
Rated power P2: 5,50 kW  
Rated current: 10,10 A  
Power factor: 0,88  
Efficiency: 50% / 75% / 100% // %  
Degree of protection: IP55  
Insulation class: F  
Motor protection

#### Fitting dimensions

Pipe connection on the suction side: DN 65, PN 16  
Pipe connection (pressure side): DN 40, PN 16  
Port to Port

#### Materials

Pump housing: 1.4301  
Impeller: 1.4301  
Shaft: 1.4301  
Shaft seal: B3Q1EF

#### Information for order placements

Weight approx.  
Item number: 9187066

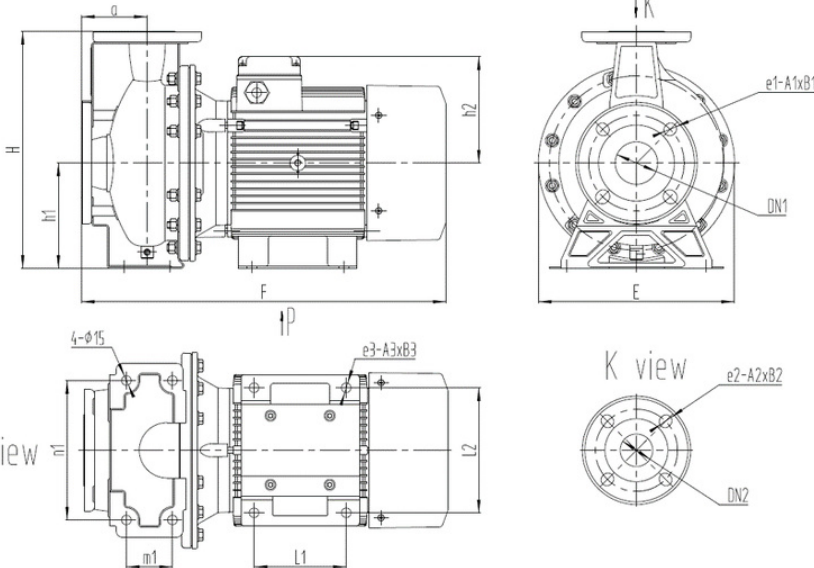

#### Dimensions

mm

A	100	H1	160	DNd	DN 40, PN 16
B1	20	H2	162		
B2	20	L1	140		
e	298	L2	190		
H	360	DNs	DN 65, PN 16		

## Hydraulic data

Glanded monobloc pump  
Atmos BST 40/200-5.5/2-V2

Project name: Untitled project 2024-07-25 06:23:36.493

Project ID  
Installation location  
Customer pos. No.

Date: 2024-07-25

### Operating data

Speed <b>2901 1/min</b>	Frequency <b>50 Hz</b>	Duty point <b>Q =</b>	<b>H =</b>	Suction port <b>DN 65</b>	Discharge port <b>DN 40</b>
----------------------------	---------------------------	--------------------------	------------	------------------------------	--------------------------------

Power data referred to: Water; 20°C; 998,3kg/m<sup>3</sup>; 1,005mm<sup>2</sup>/s ±10% tolerance with linear U/f frequency control

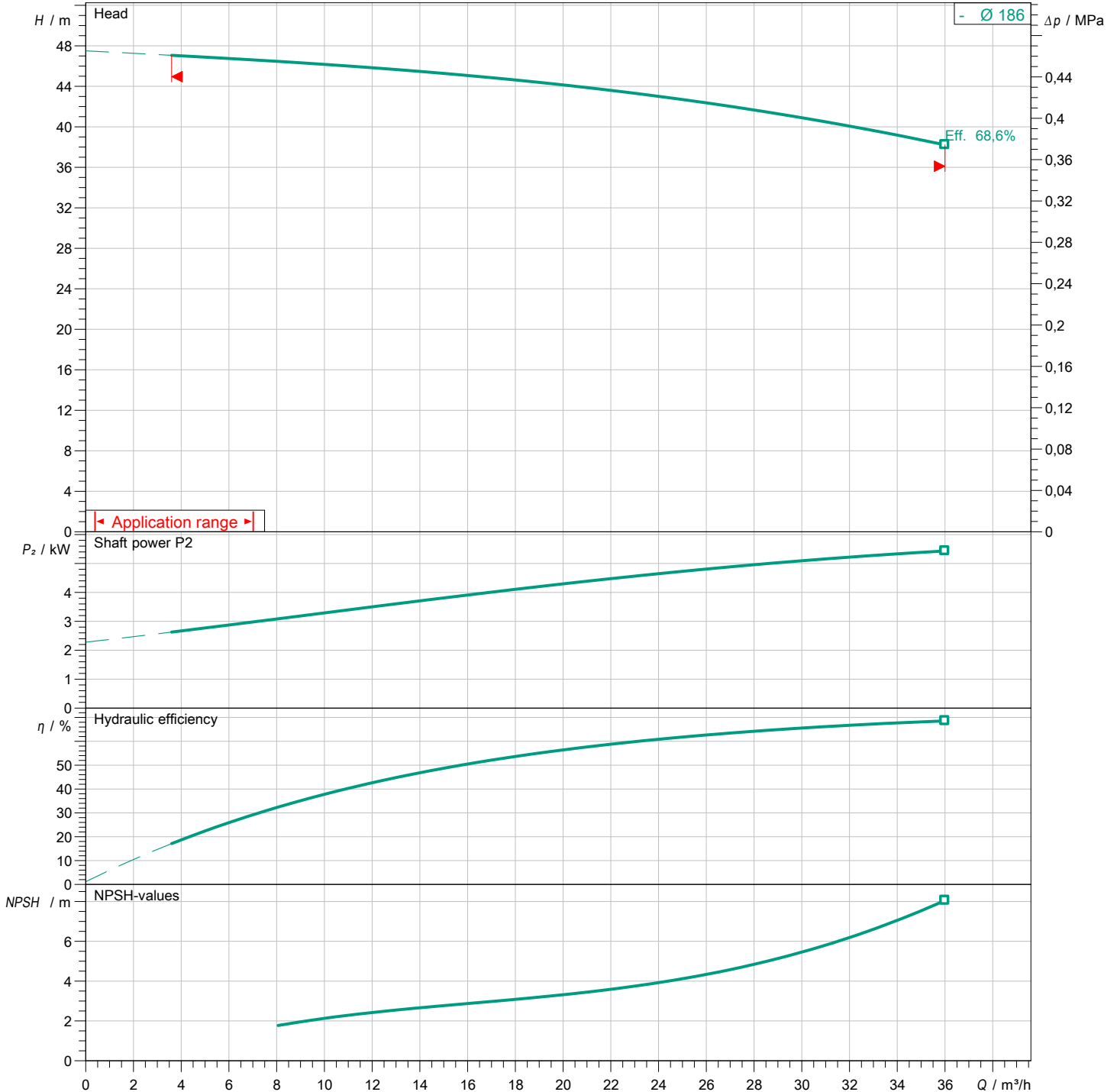

Contact  
E-mail  
Phone

**Customer**

Contact  
E-mail  
Phone

## Dimensions

Glanded monobloc pump  
Atmos BST 40/200-5.5/2-V2

Project name                      Untitled project 2024-07-25 06:23:36.493

Project ID  
Installation location  
Customer pos. No.

Date                      2024-07-25

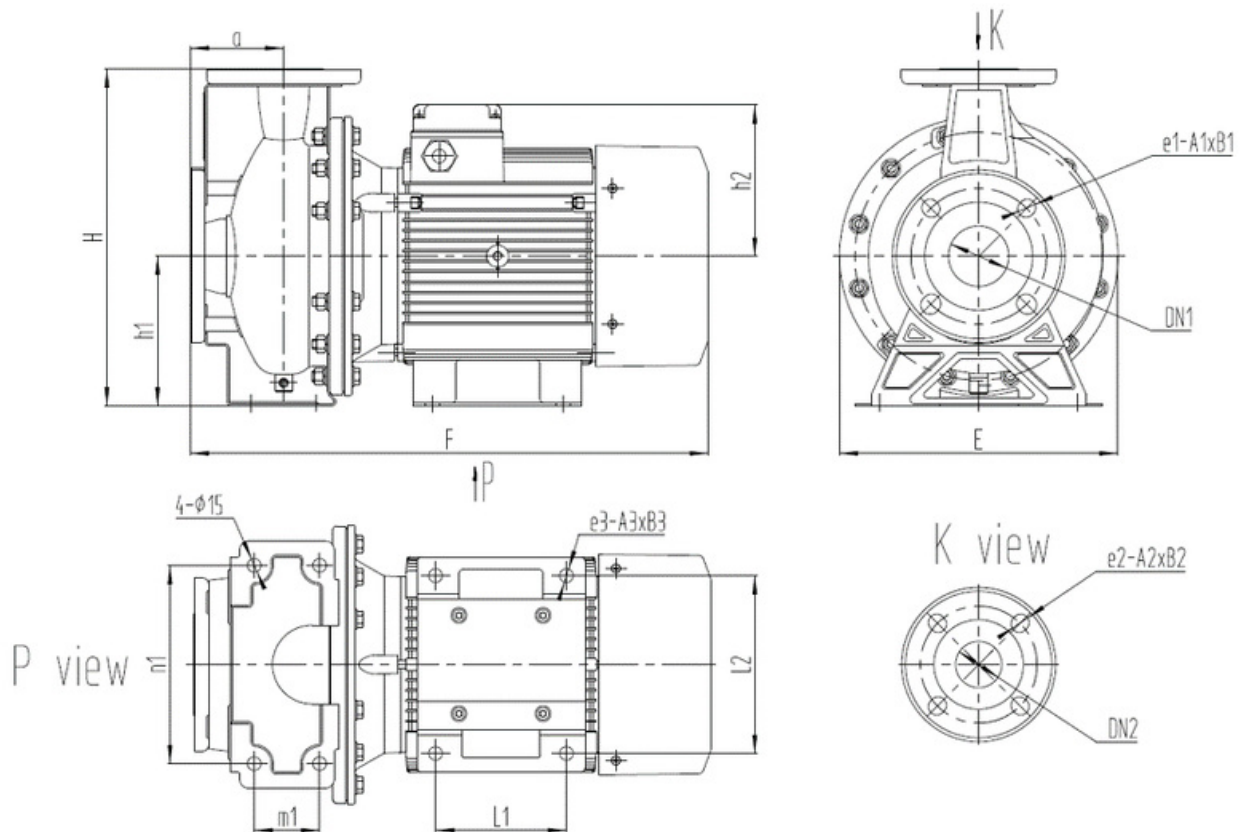

**Standard**

Suction side                      DN 65, PN 16  
Discharge side                      DN 40, PN 16

**Dimensions**                      mm

Name	Value	Name	Value	Name	Value	Name	Value
A	100	L1	140				
B1	20	L2	190				
B2	20	DNs	DN 65, PN 16				
e	298	DNd	DN 40, PN 16				
H	360						
H1	160						
H2	162						